

A B C D E F G H J K

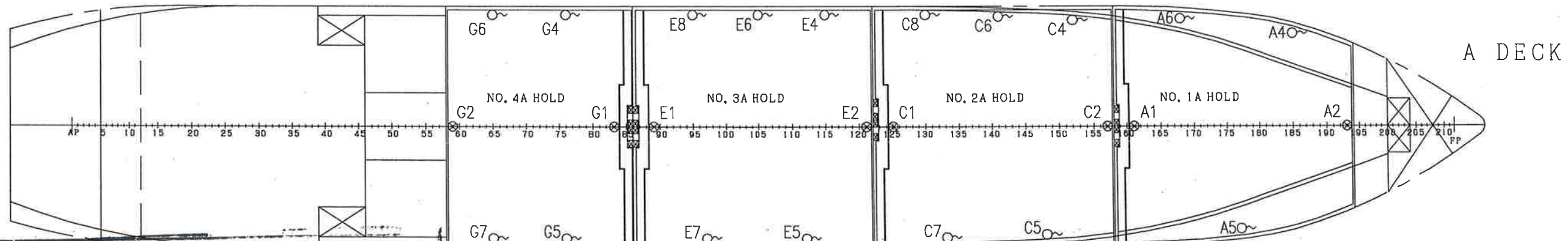
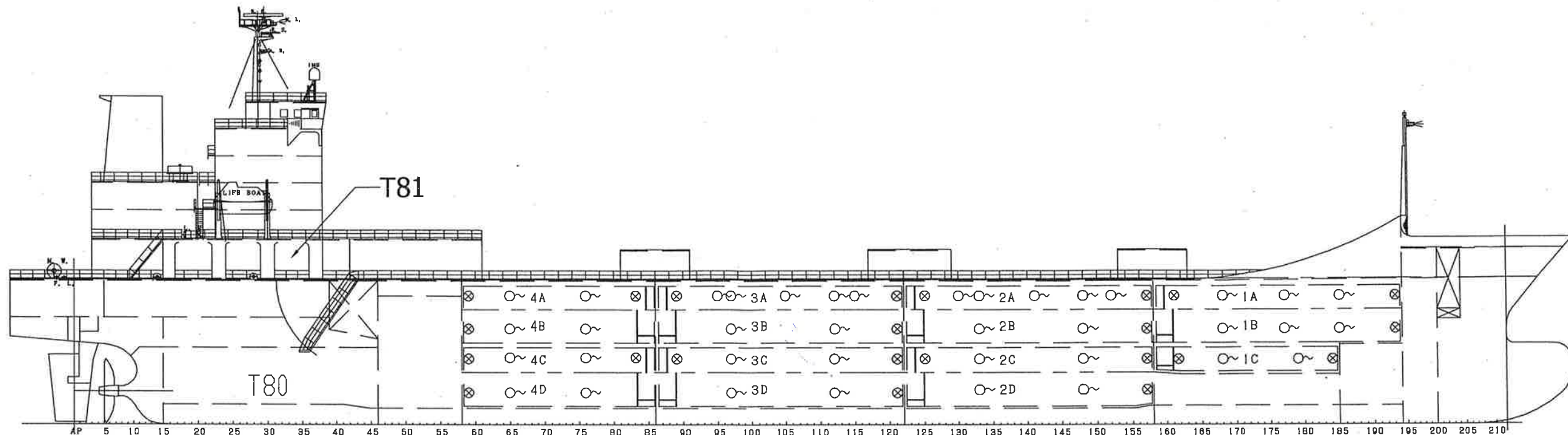

UNITED STATES DEPARTMENT OF AGRICULTURE  
 Animal and Plant Health Inspection Service  
 Plant Protection and Quarantine Programs

**APPROVED**

*Signature* *Nov 14, 2020*

Signature Date

⊗ FIXED SENSOR WITH LEAD CABLE OF 5 METERS  
 ○~ NON-FIXED SENSOR WITH LEAD CABLE OF 15 METERS

Rev No.	Description	Date	By	Appr.	Messrs. KITANIHON SHIP BUILDING CO.,LTD. SNO.671	For SENSOR ARRANGEMENT FOR USDA REPORT 1	Panel No. 05		
					Title INSTRUMENT LIST & ARRANGEMENT	Q'ty	Scale 1/450		
					<b>MAYEKAWA</b> 株式会社 前川製作所	Dwg No. 20076369-W10			
						Designed By INOUE	Drawn By MIYATA	Checked By KIMOTO	
						Date 28-May-2019	13-Jun.-2019	14-Jun.-2019	17-Jun.-2019

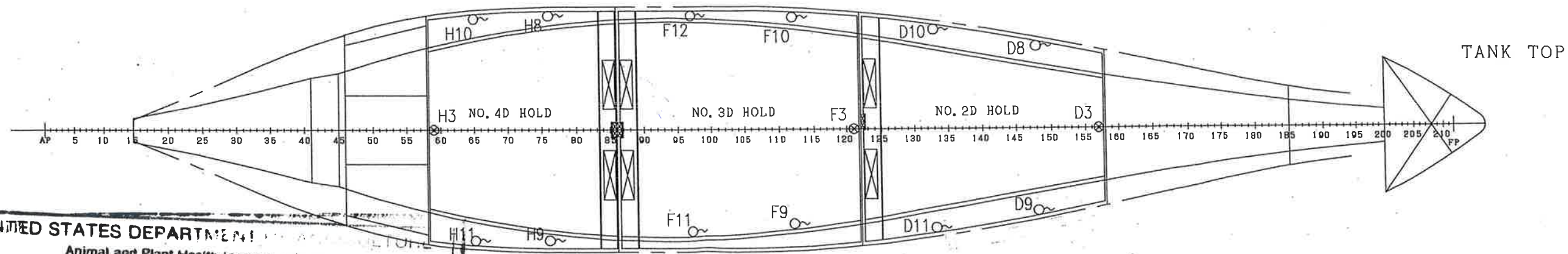
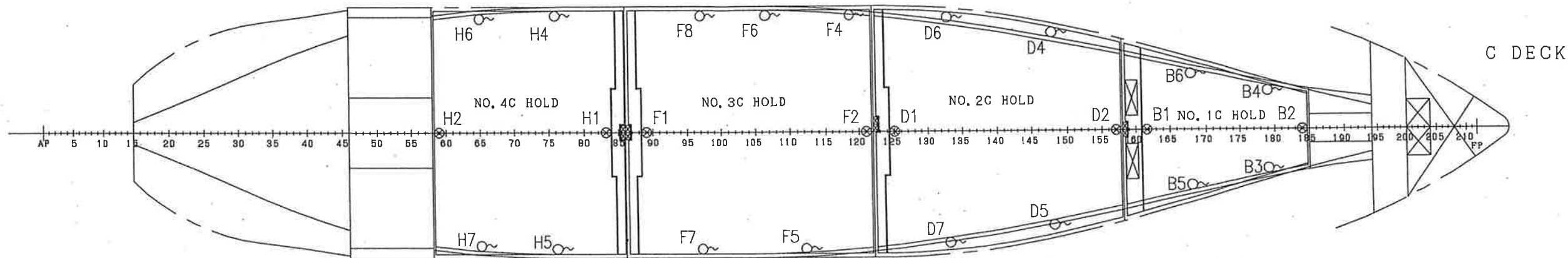
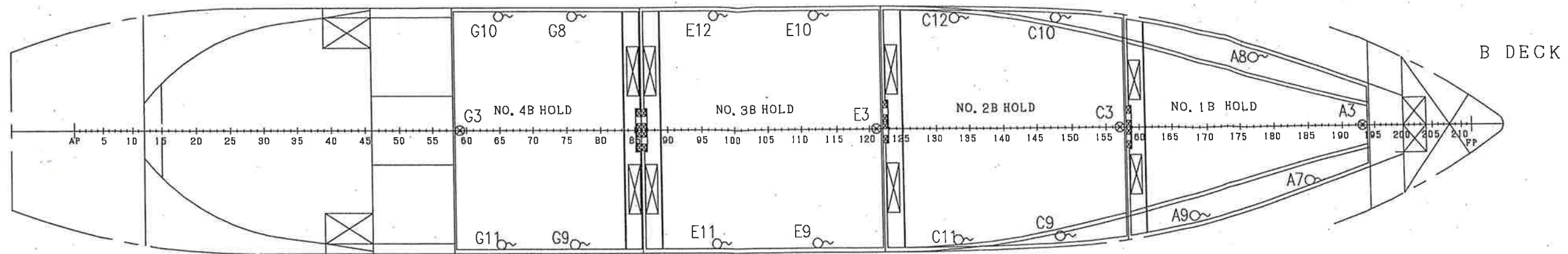

UNITED STATES DEPARTMENT OF AGRICULTURE  
 Animal and Plant Health Inspection Service  
 Plant Protection and Quarantine Programs

**APPROVED**

*[Signature]*  
 Signature  
 Date: Nov 16, 2020

⊗ FIXED SENSOR WITH LEAD CABLE OF 5 METERS  
 ○ NON-FIXED SENSOR WITH LEAD CABLE OF 15 METERS

△				Messrs. KITANIHON SHIP BUILDING CO.,LTD. SNO.671	For	SENSOR ARRANGEMENT FOR USDA REPORT 2				Panel No. 05
△				Title INSTRUMENT LIST & ARRANGEMENT	Q'ty	Scale 1/450	Dwg No. 20076369-W11			
△				<b>MAYEKAWA</b> 株式会社 前川製作所	Name	Designed By INOUE	Drawn By MIYATA	Checked By KIMOTO	Appr. By NAKAMURA	
△					Date	28-May-2019	13-Jun-2019	14-Jun-2019	17-Jun-2019	
Rev No.	Description	Date	By	Appr.	WBS No. 4-066 - 500537					

盤製作最終図面 / /